



RC CONVEYOR/SLOPE CONVEYOR



PLACING CONCRETE ACROSS FLAT SLABS OR ON SLOPES

- The GOMACO RC Conveyor is designed to place concrete across flat slabs or on slopes up to 135 ft. (41.15 m) wide.
- Designed with lattice-type, structural angle-iron frame with pin-connected sections which are interchangeable in 12 ft. (3.66 m), 6 ft. (1.83 m) and 3 ft. (.91 m) increments for fast setup and easy assembly.
- Conveyor with standard, double-flanged, steel trolley wheels runs on any type of rail system or paving forms. Traction speed is variable up to 38 fpm (11.58 mpm), forward and reverse.
- The bogies are designed to allow the frame to be set at any skewed angle up to 55 degrees. The travel speed of each bogie is independently controlled to allow negotiation through radii.
- The RC Conveyor includes self-widening capability for use on tapered decks and slabs.
- Concrete is discharged directly into receiving hopper from Ready Mix trucks.
- The diverter car discharges to the front or rear and is operated by hydraulically powered, positive chain drive. Variable hydraulic control of diverter car and of machine travel assures even and accurate placement of concrete.
- The conveyor is counterbalanced with console and receiving hopper at opposite ends, removing operator from congested area of receiving hopper.
- The self-contained console has easy-to-operate controls. The RC Conveyor is powered by a 70 hp (52.2 kW) diesel engine.

ENGINE

Type: Cummins diesel.

Horsepower: 70 hp (52.2 kW) @ 2100 rpm.

SERVICE CAPACITIES

Fuel reservoir: 33 gal. (124.9 L).

Hydraulic oil: 57 gal. (215.8 L).

HYDRAULIC SYSTEM

Pump: One dual stage main pump provides 30 gpm (113.6 Lpm) @ 2100 rpm.

Hydraulic oil cooling: One air-to-oil cooler.

Filtration: One 10-micron, return line filter.

BELT SYSTEM

Width: 24 in. (610 mm) belt.

Belt speed: 528 fpm (160.93 mpm).

Belt rollers: 20 degree, tapered roller cones support upper belt.

Diverter car discharge: Front or rear.

Diverter car speed: Up to 131 fpm (39.93 mpm).

TRACTION SYSTEM

Traction speed: Up to 38 fpm (11.58 m) forward or reverse with standard bogies.

Traction drive: Hydraulically powered, two double-flanged, 8.6 in. (218 mm) diameter, steel trolley wheels, skewable.

CONSTRUCTION

Frame: Lattice-type, structural angle-iron with pin-connected sections interchangeable in 12 ft. (3.66 m), 6 ft. (1.83 m) and 3 ft. (.91 m) sections.

FRAME DEPTH AND PLACING WIDTH

24 in. (610 mm) frame depth for spans up to 75 ft. (22.86 m).

32 in. (813 mm) frame depth for spans up to 135 ft. (41.15 m).

SLOPE ADAPTERS

Frame to bogie per customer specifications.

WEIGHTS for 24 in. (610 mm) frame depth.

27 ft. (8.23 m) unit: 7,318 lbs. (3,319 kg).

12 ft. (3.66 m) extension: 900 lbs. (408 kg).

6 ft. (1.83 m) extension: 465 lbs. (211 kg).

3 ft. (.91 m) extension: 260 lbs. (118 kg).

WEIGHTS for 32 in. (813 mm) frame depth.

27 ft. (8.23 m) unit: 7,638 lbs. (3,465 kg).

12 ft. (3.66 m) extension: 945 lbs. (429 kg).

6 ft. (1.83 m) extension: 488 lbs. (221 kg).

3 ft. (.91 m) extension: 273 lbs. (124 kg).

OPTIONS

70 hp (52.2 kW) CAT diesel engine.

Two 4-wheel end cars, flanged flat or cupped wheels.

6 in. (152 mm) and 12 in. (305 mm) frame elevators.

Transport assembly with transport axle, 6.7 in. (170 mm) by 15 in. (381 mm) 6-ply tires and towing tongue for job site use only.

Crawler tracks, 11 ft. 7 in. (3.53 m) long, hydraulically driven with 11.8 in. (300 mm) wide pads with street grousers. 36:1 gear reduction.

Rubber tired bogies, hydraulically driven, foam-filled flotation tires, 26 in. (660 mm) diameter by 12 in. (305 mm) wide.

Telescoping tremie.

Slope wedges.

Other options are available to customize machine to accommodate applications and customer needs.

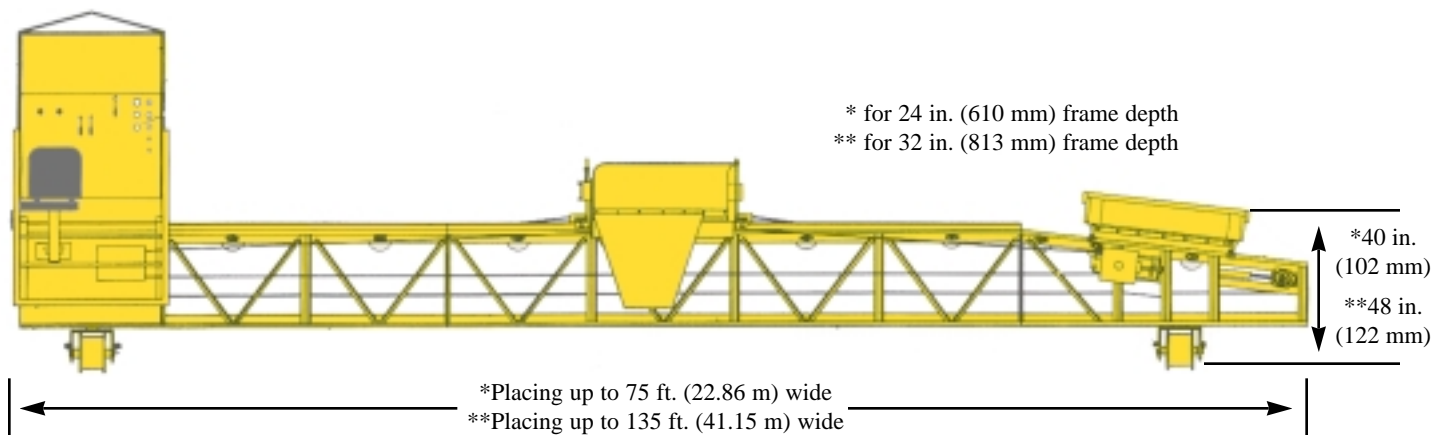

MANUFACTURED UNDER ONE OR MORE OF THE FOLLOWING U.S. OR FOREIGN PATENTS: 3,299,786; 3,450,011; 3,541,931; 3,779,661; 3,959,977; 4,073,592; 4,136,993; 4,226,917; 4,343,513; 4,360,293; D-266,850; 853,607; 861,819; 954,773; 406,787; 1,147,187; 133,220; D-512,249; 4,717,282; 4,457,645; C-1,110,893; C-1,191,044; 12,890-1-0010; 5,061,115; 7,509,187; 7,509,615; 5,102,267; 5,101,360; 4,954,019; 4,984,639; 5,190,397; 5,209,602; 0518535, 2067126 AND PATENTS PENDING.

GOMACO Corporation reserves the right to make improvements in design, material, and/or changes in specifications at any time without notice and without incurring any obligation related to such changes.

Printed in U.S.A. © 1997 (4 AP) GOMACO Corporation Order #0335-0A10140

GOMACO International LTD.
769 Buckingham Avenue
Trading Estate, Slough
SL1 4NL Berkshire, England
Phone: 44-1753-821926
Fax: 44 . 1753 . 693093

GOMACO Corporation
GOMACO International
Ida Grove, Iowa U.S.A. 51445
Phone: 712-364-3347
Fax: 712 . 364 . 3986
E-mail: info@gomaco.com